

Flexible Mobile Fronthauls: Towards Next Generation Radio Access Network

Optical Communication Systems

Background and challenges

- As a promising architecture for next radio technology, 5G imposes tight requirements on the Mobile Fronthaul (MFH) as regards line rate, latency and jitter-. This work therefore attempts to propose and investigate dynamic MFH that adapts to the users traffic requirements.

Description and main innovation

- The research work aligns with the contexts of the ORCIP infrastructure and Mobilizador 5G Projects and to address the aforementioned challenges, it focuses on:
 - ✓ Analysis of CRAN transport solutions
 - ✓ Evaluation of existing proposed functional splits
 - ✓ Investigation and Implementation of eCPRI interface with OpenAirInterface (OAI)
 - ✓ Investigation and implementation of Ethernet based Fronthaul (EFH)
 - ✓ Analysis of the effect of the function split options on EFH
 - ✓ orchestration of EFH and NG-PON2

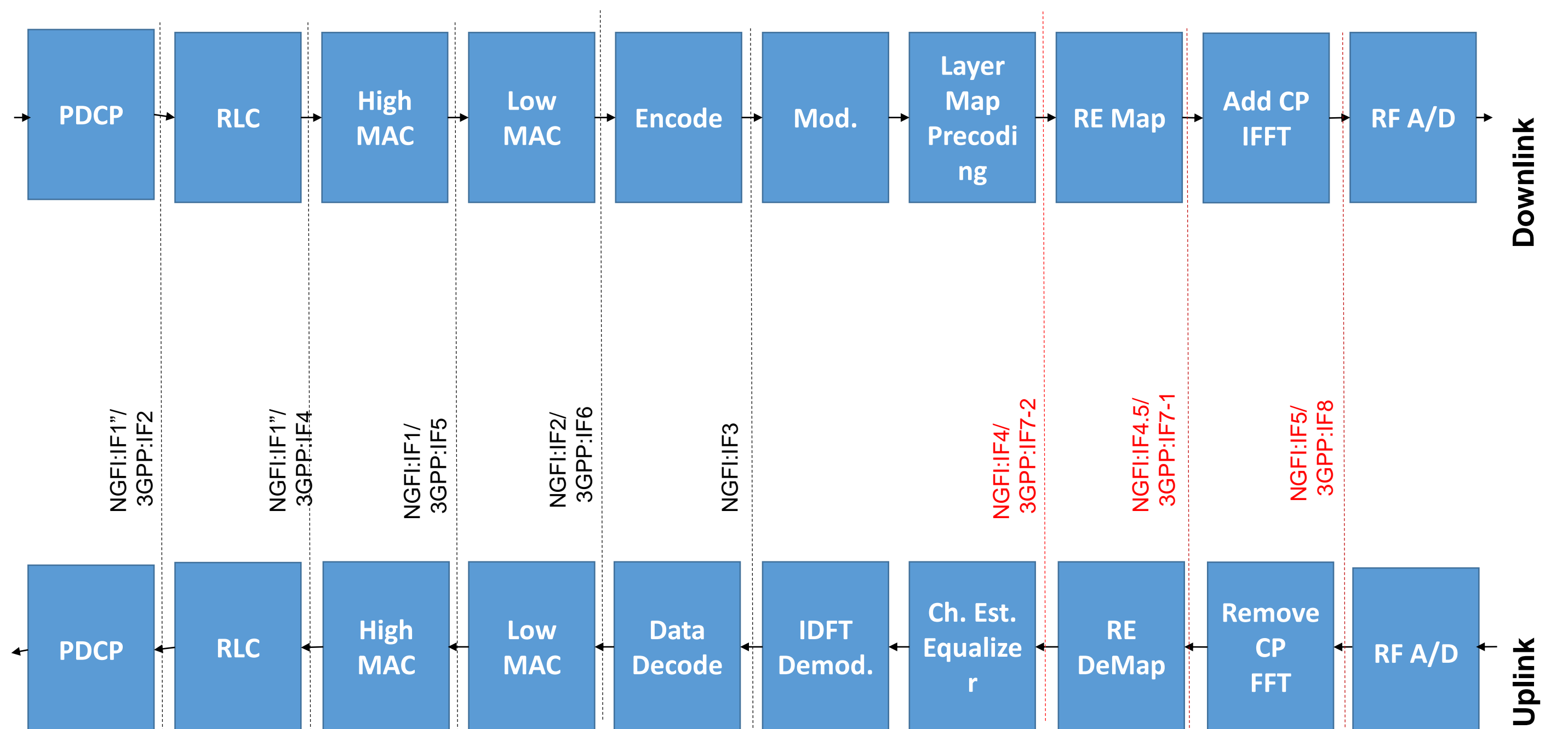

Fig. 1: Functional split options

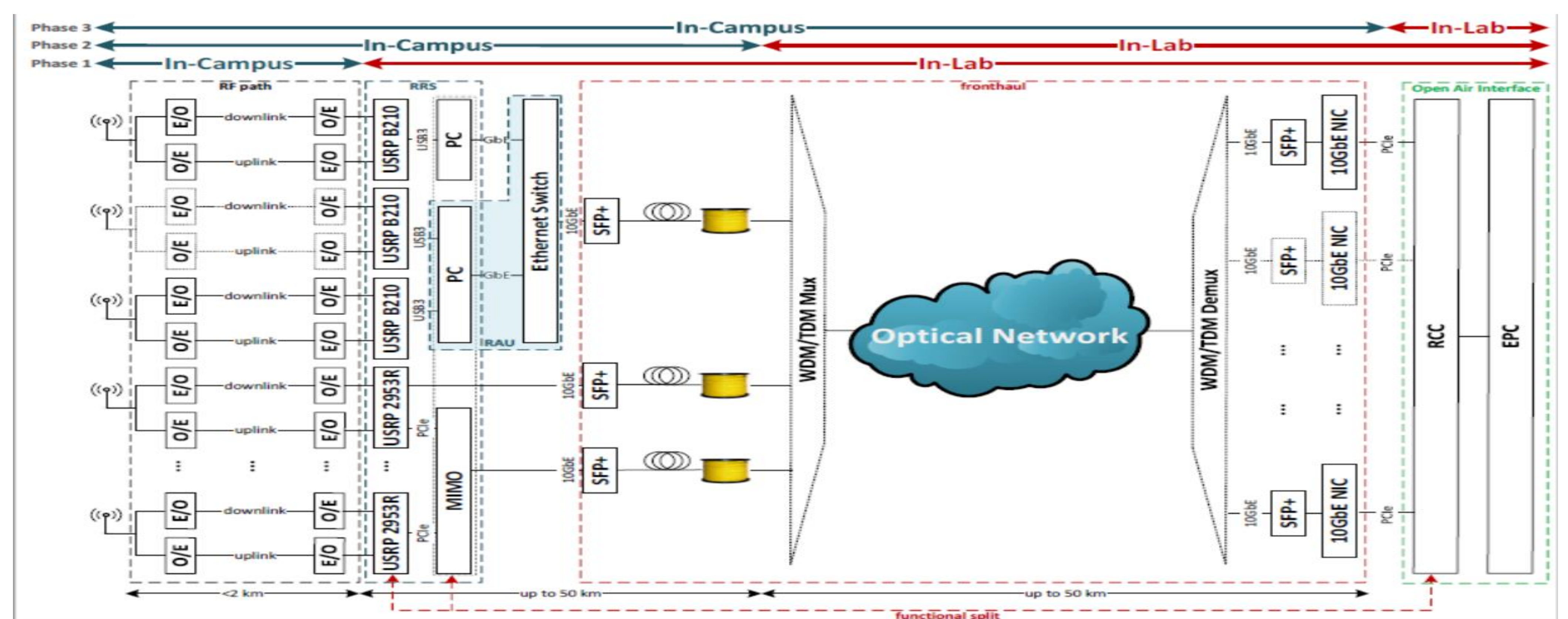

Fig. 2: Proposed ORCIP architecture

Achievements

- Two operating setups based on OAI have been developed for LTE as a contribution to ORCIP framework:
 - ✓ Analysis of Split 8: USRP NI-2953R + BBU + EPC with 10G SFP+ Optical Interface operating on 5MHz, 10MHz and 20MHz bandwidth
 - ✓ Split 7-1: USRP B210 + RRU + RCC + EPC, presently achievable bandwidth of 5MHz and 10MHz.